



Department for
Digital, Culture,
Media & Sport

 Department for Digital, Culture, Media & Sport

**GIGABIT BROADBAND
VOUCHER SCHEME**



Supplier Terms and Conditions

Gigabit Broadband Voucher Scheme

20 May 2019

Version 5.0

Contents

PART A: INTRODUCTION	3
PART B: CORE TERMS.....	4
1 Application of these Terms and Conditions.....	4
2 RGC Projects and other projects.....	4
3 Additional guidance	4
4 Provision of information	4
5 Supplier status and capability.....	5
6 Pre-Registered Packages.....	5
7 Engagement with Beneficiaries.....	7
8 Connectivity Requirements and Eligible Costs.....	8
9 Voucher requests and payment claims.....	8
10 Validity and expiry of vouchers.....	9
11 Reporting.....	9
12 Audit and value for money	10
13 Scheme variation and cessation	10
14 Information sharing	11
15 Personal data	11
16 Anti-competitive behaviour	13
17 Waiver.....	13
18 Severance.....	13
19 Governing law	13
SCHEDULE 1 - DEFINITIONS.....	14
SCHEDULE 2 - BENEFICIARY ELIGIBILITY.....	18
SCHEDULE 3 - CONNECTIVITY REQUIREMENTS	21
SCHEDULE 4 - ELIGIBLE COSTS	22
SCHEDULE 5 - SCHEME MARKETING AND PROMOTION PROTOCOL.....	27
SCHEDULE 6 - ISSUE ESCALATION PROCEDURE	29
SCHEDULE 7 - RGC PROJECTS.....	31
SCHEDULE 8 - ADDITIONAL FUNDING.....	32

Part A: Introduction

The Gigabit Broadband Voucher Scheme (the "**Scheme**") is part of the Local Full Fibre Networks (LFFN) programme and the Rural Gigabit Connectivity (RGC) programme and is managed by BDUK.

The Scheme operates across the whole of the UK.

The purpose of the Scheme is to increase the speed of deployment of full fibre networks within the UK by providing micro-grants to support the cost of new connectivity. Vouchers are the mechanism the Scheme uses to provide these grants. The Scheme aims to encourage Suppliers to invest in Gigabit Capable services. The voucher is a benefit to eligible Beneficiaries who must receive the full value of the voucher.

Using their grant, Beneficiaries are able to contract with Suppliers for Gigabit Capable products (referred to in the Scheme as Pre-Registered Packages). This is the only mechanism by which a Beneficiary can take a voucher.

Payments of grant to Beneficiaries under the Scheme are made by the Authority direct to Suppliers, once they have confirmed that new connections have been delivered, although the Beneficiary is the recipient of the new connection and the beneficiary of the grant.

Following the precedent of the BDUK Super-Connected Cities Voucher Scheme, payments for vouchers issued are made under the terms of the European Commission's "De-Minimis" Regulation (1407/2013).

Part B: Core Terms

1. Application of these Terms and Conditions

1.1 Suppliers agree to comply with these Terms and Conditions:

1.1.1 as a condition of their participation in the Scheme and the issue of vouchers for the benefit of relevant Beneficiaries; and

1.1.2 for the duration of their participation in the Scheme.

1.2 The Authority may, at any time, contact any referee named by Suppliers in connection with their applications for registration to the Scheme.

1.3 Use by the Suppliers of any third party sales or delivery agent on their behalf in no way alters the responsibility of the Suppliers to comply with these Terms and Conditions.

1.4 Unless otherwise provided or the context otherwise requires:

1.4.1 in these Terms and Conditions references to clauses are references to clauses of these Terms and Conditions in this Part B and references to paragraphs are references to paragraphs in the relevant Schedules to these Terms and Conditions; and

1.4.2 capitalised terms used in these Terms and Conditions have the meanings set out in Schedule 1 – Definitions.

2. RGC Projects and other projects

2.1 Certain additional, amended or replacement terms applicable to:

2.1.1 RGC Projects are set out in Schedule 7 – RGC Projects; and

2.1.2 other projects are set out in Schedule 8 – Additional Funding.

3. Additional guidance

The Authority may provide Suppliers with Additional Guidance regarding the operation of the Scheme which, if so provided, Suppliers shall comply with. In the event of any conflict between the Additional Guidance (or any other Authority guidance or information including as set out on the Scheme website) and these Terms and Conditions, these Terms and Conditions shall take precedence.

4. Provision of information

4.1 Suppliers:

4.1.1 confirm that any information provided to the Authority in connection with the Scheme is correct to the best of their knowledge and belief;

4.1.2 acknowledge that providing wrong or deliberately misleading information in connection with the Scheme may give rise to criminal or other legal consequence

and the application of the Issue Escalation Procedure including de-registration from the Scheme;

4.1.3 shall provide the Authority with such additional information and assistance as the Authority may reasonably require from time to time in relation to the operation of the Scheme; and

4.1.4 shall provide the Authority with details of the Supplier Contact (who shall have overall responsibility for the Supplier's operational involvement in the Scheme and oversight of any other persons involved in the sales, delivery, reporting and management of connections delivered by the Supplier with support from the Scheme).

5. **Supplier status and capability**

5.1 Subject to clause 5.2, Suppliers:

5.1.1 confirm that for the duration of their participation in the Scheme they:

(a) are capable of entering into contractual relationships with Beneficiaries for the delivery of connections which meet the Connectivity Requirements;

(b) are registered for VAT;

(c) are not sole traders; and

(d) hold annual public liability insurance of at least £5,000,000 per event;

5.1.2 acknowledge that the Authority does not offer any opinion on the capability of Suppliers and Suppliers shall not make any representations to that effect;

5.1.3 must inform the Authority immediately of any change in circumstances which may affect their registration to, or participation in, the Scheme;

5.1.4 acknowledge that any failure to notify the Authority of any material change in their status, applicable product costs and/or their performance capability shall constitute a material breach of these Terms and Conditions and will be subject to the Issue Escalation Procedure which may result in the suspension or removal of the Supplier from the Scheme.

5.2 The Authority reserves the right to amend or substitute the requirements set out in clause 5.1.1 if the Supplier is a community-based or similar non-commercial organisation.

5.3 Non-participation by Suppliers in the Scheme (such as the continued refusal to offer services to Beneficiaries when requested, without reasonable explanation or cause) may be considered a breach of these Terms and Conditions and managed in accordance with the Issue Escalation Procedure.

6. **Pre-Registered Packages**

6.1 As a condition of their participation in the Scheme, Suppliers shall provide details of their proposed Pre-Registered Packages (being packages of eligible products the Suppliers wish to

offer as part of the Scheme) for authorisation by the Authority using the Pre-Registered Package application form and procedure provided by the Authority. Any proposed Pre-Registered Packages must be fully compliant with the relevant Terms and Conditions and any costs claimed in respect of authorised Pre-Registered Packages must genuinely be incurred and be Eligible Costs only.

- 6.2 Each Pre-Registered Package application must demonstrate how the value of the voucher grant will be realised in full by the Beneficiaries. The voucher should only be used to fund (or part-fund) a connection charge (non-recurring charge) associated with a commercially-available product that would otherwise be paid by customers (either individually or collectively). Suppliers should not use voucher funding to discount their standard monthly (recurring) charges to Beneficiaries. Suppliers should include an analysis of the standard market price to the Beneficiaries in the absence of vouchers (and provide appropriate evidence), and details of how this compares to the price reflecting the voucher contribution. Any documents provided (along with any subsequent amendments or clarifications sought by the Authority) will form part of the relevant application and may be incorporated within any subsequent authorisation documents provided by the Authority.
- 6.3 A fundamental principle of the Scheme is that the Beneficiaries are the financial beneficiaries of the Scheme and must receive the full value of their respective voucher grants. All proposed Pre-Registered Packages are therefore subject to commercial assessment to ensure that the benefit to Suppliers for voucher-funded deployments is no greater than for non-voucher projects. For all Suppliers this may involve an assessment of the project submission to ensure that the voucher contribution is not substitutional for investment which the Supplier would normally make, and represents a contribution that would otherwise be provided by Beneficiaries.
- 6.4 Suppliers will be notified by the Authority in writing when any proposed Pre-Registered Package has been authorised and upon such authorisation the proposed Pre-Registered Package shall be deemed to be a Pre-Registered Package for the purpose of the Scheme. This notification will include confirmation of the value of the voucher grant applicable for each package. Suppliers must not offer proposed Pre-Registered Packages to Beneficiaries until they have been authorised by the Authority in writing.
- 6.5 For SME Beneficiaries vouchers have a minimum value of £500 and a maximum value of £2,500.
- 6.6 Where the Eligible Costs of connecting a Beneficiary are less than £500, no voucher funding will be made available.
- 6.7 For Residential Beneficiaries vouchers have a fixed value of £500. Residential Beneficiaries may only benefit from a Pre-Registered Package where that package is: i) a Project PRP; and ii) the number of vouchers offered to residential Beneficiaries must not exceed a ratio of 10:1 compared to the number of vouchers offered to SME Beneficiaries in respect of the relevant Pre-Registered Package.
- 6.8 Vouchers cannot fund VAT which shall remain the responsibility of the Beneficiaries.
- 6.9 The Authority reserves the right to limit the number of Pre-Registered Packages it will agree for any Supplier at its absolute discretion. Non-exhaustive examples of the factors that the Authority may take into account include the relevant Supplier's ability to deliver the Pre-Registered Packages as well as financial risk and market considerations.

- 6.10 Once a Pre-Registered Package has been authorised by the Authority, the relevant Supplier may market the Pre-Registered Package to Beneficiaries. For Project PRPs the package must only be marketed in the area authorised by the Authority.
- 6.11 Authorisation by the Authority of a Pre-Registered Package does not guarantee funding will be made available to support any connections within that package. Payment will only be made for vouchers issued by the Authority as part of Pre-Registered Packages where compliant connections are delivered to Beneficiaries who (i) agree to redeem the grant made available through the offer of a voucher; (ii) have agreed to the Beneficiary Terms and Conditions; and (iii) have verified their connections.
- 6.12 The maximum aggregate value of all vouchers issued for a single Project PRP is capped at £500,000 and no further vouchers will be issued for any Project PRP where this value has been reached in respect of that Project PRP.
- 6.13 Project PRPs may only be delivered within the locations set out in the relevant Pre-Registered Package application that has been authorised by the Authority in accordance with clause 6.4.
- 6.14 Suppliers may not make any material changes to any authorised Pre-Registered Package without the prior written consent of the Authority, which consent shall not be unreasonably withheld or delayed.
- 7. Engagement with Beneficiaries**
- 7.1 Prior to requesting vouchers, Suppliers shall establish the eligibility of Beneficiaries using the criteria set out in Schedule 2 – Beneficiary Eligibility.
- 7.2 Suppliers may not enter into Beneficiary Contracts:
- 7.2.1 if they are aware that the Beneficiary does not meet the eligibility criteria set out in Schedule 2 – Beneficiary Eligibility;
- 7.2.2 until the applicable Pre-Registered Package has been authorised by the Authority in accordance with clause 6.4.
- 7.3 Each Beneficiary Contract must be in writing and have a minimum contract period of 12 months and no free periods and/or discounts against standard monthly (recurring) charges may be offered to Beneficiaries.
- 7.4 The financial benefit of vouchers must be passed on in full to the relevant Beneficiaries.
- 7.5 The Authority gives no undertaking or accepts any liability for the ability or willingness of individual Beneficiaries to enter into Beneficiary Contracts, or for the authority of individual Beneficiaries to authorise connections at specific Premises. Suppliers are advised to exercise usual due diligence best practice before entering into Beneficiary Contracts.
- 7.6 Suppliers acknowledge that they participate in the Scheme (including offers and performance of Beneficiary Contracts) at their own cost and risk and that the Authority cannot bind Beneficiaries to Beneficiary Contracts.
- 7.7 Pre-Registered Packages (and associated Eligible Costs) must be sold to Beneficiaries solely on the basis of the relevant Beneficiary's need in accordance with standard market practice.

- 7.8 Vouchers will not be issued for Premises that have received (or are scheduled to receive within 12 months) a connection which meets the Connectivity Requirements as part of a previous (or planned) State Aid Intervention.
- 7.9 When promoting Pre-Registered Packages to potential or actual Beneficiaries, Suppliers must do so in a way which makes clear the source and nature of the financial support offered to the Beneficiaries and in compliance with Schedule 5 – Scheme Marketing and Promotion Protocol. Suppliers shall provide each of their Beneficiaries with a clear statement of facts about the Scheme, taking account of any guidance that the Authority may provide in this regard.
- 7.10 Additional terms apply relating to how the Scheme is referenced and credited in Supplier sales and marketing material, including websites and other forms of electronic communication. These are set out in Schedule 5 – Scheme Marketing and Promotion Protocol.

8. Connectivity Requirements and Eligible Costs

- 8.1 Claims for funding under the Scheme must only be for:
- 8.1.1 connections that comply with the Connectivity Requirements; and
 - 8.1.2 Eligible Costs.
- 8.2 Any Eligible Costs claimed must be consistent with those charged to customers without the benefit of voucher support. Suppliers will be in breach of these Terms and Conditions if they make claims for Eligible Costs which are greater than those which otherwise would have been charged to the relevant Beneficiary had a voucher not been in place.

9. Voucher requests and payment claims

- 9.1 There is a three step process in respect of the treatment of vouchers and their payment:
- 9.1.1 Step 1: Suppliers initially submit requests for vouchers (based on the funding provided in the relevant authorised Pre-Registered Package) prior to the delivery of the relevant connections.
 - 9.1.2 Step 2: The Authority issues vouchers for the benefit of the relevant Beneficiaries.
 - 9.1.3 Step 3: Suppliers submit payment claims for the vouchers issued under Step 2 once the relevant connections have been delivered. Suppliers should note that the Authority's authorisation of any Pre-Registered Package is not a guarantee of funding support under the Scheme and that the Authority will only make payments in respect of vouchers which are issued by the Authority under Step 2.
- 9.2 Suppliers must obtain the consent of the relevant Beneficiary prior to submitting requests for vouchers. Submitting requests for vouchers without the relevant consent will be regarded as a breach of these Terms and Conditions and will lead to the initiation of the Issue Escalation Procedure.
- 9.3 The Authority will contact each Beneficiary before vouchers are issued in order to verify their acceptance of the Beneficiary Terms and Conditions and to confirm their eligibility details. If the Authority does not receive verification from a Beneficiary for whom a voucher has been

requested within **28 days** of the date of request, the Authority may at its absolute discretion cancel the voucher requested. Suppliers must notify Beneficiaries of this step in the process.

9.4 Requests for vouchers and payment claims submitted to the Authority which reference a specific Pre-Registered Package must be delivered using only the cost inputs, commercial terms, technology, equipment and network architecture set out in the relevant Supplier's authorised Pre-Registered Package and any variation from those details not agreed in advance with the Authority will constitute a breach of these Terms and Conditions and result in the initiation of the Issue Escalation Procedure.

9.5 Before a voucher payment can be made the relevant Beneficiary must verify that the connection has been delivered. If the Authority does not receive this verification within **28 days** of the date on which a connection has been reported, the Authority will place the voucher at risk and notify the relevant Supplier. Payments will not be made for connections where this verification has not been obtained. The Authority may at its absolute discretion subsequently refuse to accept the relevant payment claim and cancel the voucher. Suppliers must notify Beneficiaries of this step in the process.

9.6 The Authority may at its discretion carry out a site audit visit before any voucher payment is made and in such cases the Authority will arrange for the site visit to take place as soon as possible. Suppliers should continue to provide reports in accordance with these Terms and Conditions until payments have been received for all connections.

9.7 The Authority will aim to make voucher payments to Suppliers within 10 Working Days of the later of:

9.7.1 the receipt of the relevant Beneficiary's validation that the connection has been delivered; or

9.7.2 the successful completion of any applicable site audit visit pursuant to clause 9.6.

10. **Voucher validity and payment claims period**

10.1 Vouchers may not be requested for compliant connections that have already been delivered. Voucher funding is not available retrospectively.

10.2 All connections must be delivered and voucher claims submitted for payment no later than **12 months** from the issue date of the relevant voucher(s). If Suppliers believe that, during the 12 month implementation period, this timeframe is at risk due to issues caused by third parties beyond their reasonable control and which could not be reasonably foreseen (and the Suppliers have acted in accordance with good industry practice), then Suppliers should contact the Authority as soon as is practicable with details of the mitigating circumstances, including details of the relevant issue(s) and the earliest delivery date which can be achieved. The Authority will consider the evidence provided and may, at its sole discretion, agree a revised claim deadline for the voucher(s).

11. **Reporting**

11.1 Suppliers shall provide the reporting information set out in Schedule 2 – Beneficiary Eligibility concerning sales, cancellations and connections delivered utilising the relevant Pre-Registered Package. Failure to do so with reasonable accuracy, and within the timescales set out in Schedule 2 – Beneficiary Eligibility, constitutes non-compliance with these Terms and Conditions which will be managed in accordance with the Issue Escalation Procedure. The

Authority reserves the right not to make payments in respect of vouchers where the relevant Supplier fails to complete and submit reports in accordance with these Terms and Conditions.

11.2 Suppliers may be required to provide additional information about the impact and benefit of the Scheme and shall use their reasonable endeavours to comply in a timely manner with all reasonable requests from the Authority to provide additional information during (and for a reasonable period after) the Scheme. Suppliers will provide the information regarding "additionality" (where relevant) as set out in the application form for Pre-Registered Packages.

11.3 Where Beneficiary Contracts or connections are not reported to the Authority within 10 days of the date of the relevant Beneficiary Contract, the Authority reserves the right not to issue a voucher to the relevant Beneficiary, or to make payment for the connection whichever is applicable. Failure to report the cancellation of any Beneficiary Contract for which a voucher has been issued within this timescale may be regarded as a breach of these Terms and Conditions and result in the initiation of the Issue Escalation Procedure.

12. **Audit and value for money**

12.1 As part of the Authority's anti-fraud procedures, Supplier quotes, Beneficiary Contracts and invoices will be subject to random audit. In addition, at the sole discretion of the Authority any services provided under Beneficiary Contracts may be subject to further clarification or inspection for audit purposes. Where further clarification is required by the Authority, its appointed agents and/or local bodies, Suppliers will be required to provide evidence that costs against which voucher funding has been claimed have been legitimately incurred and relate to Eligible Costs only (including evidence where requested by the Authority of input costs from the relevant wholesale infrastructure provider). This information shall be provided by Suppliers within 5 Working Days of any request by the Authority. Where appropriate, the Authority will follow the Issue Escalation Procedure.

12.2 Where the Authority and/or local bodies suspect or identify fraud, malpractice and/or Supplier error and have carried out the steps described in the Issue Escalation Procedure, the Authority reserves the right to withdraw or recover voucher funds from the relevant Supplier and/or remove the Supplier from the Scheme at its absolute discretion.

12.3 On a sampled basis, the Authority and/or its agents will conduct pre and post-installation checks with Beneficiaries. Suppliers may be required to provide photographic or other evidence of relevant installations. In the case of Supplier error (e.g. where a Pre-Registered Package has erroneously been supplied to an ineligible Beneficiary on the basis of information provided by that Beneficiary), the Authority may choose to carry out the steps described in the Issue Escalation Procedure and the Authority reserves the right to recover voucher funds from the relevant Supplier (or retain funding). Where post-installation checks have identified that a Beneficiary has provided incorrect information to a Supplier and the Authority takes action to recover voucher funding, then the relevant Supplier shall provide reasonable assistance to the Authority to facilitate recovery of grant funding from the Beneficiary.

13. **Scheme variation and cessation**

13.1 The Authority may:

- 13.1.1 amend these Terms and Conditions and the associated Scheme processes from time to time. Suppliers will be notified in writing in advance with details of any proposed changes and will be given the option to accept the proposed changes or de-register from the Scheme;
- 13.1.2 suspend (for any period) or cease the Scheme at any time upon notice to the Supplier Contacts, in which case the Authority will:
- (a) not accept requests for vouchers for the period of the suspension or after the date and time of the cessation; and
 - (b) make payments for voucher payment claims submitted (including during the period of suspension or after the date and time of the cessation) in respect of vouchers that have been issued by the Authority prior to the date and time of the suspension or cessation, subject to and in accordance with these Terms and Conditions and provided that voucher funding remains available; and
- 13.1.3 de-register, suspend or amend Pre-Registered Packages at any time during the Scheme and carry out reviews of Pre-Registered Packages at its absolute discretion. If Pre-Registered Packages are amended by the Authority, this will be notified to relevant Suppliers in writing at least 2 Working Days prior to the effective date of such amendments.
- 13.2 If the Authority requires the use of Pre-Registered Packages to cease then no new Beneficiary Contracts may be entered into after the period of 2 Working Days following formal notification from the Authority. In these circumstances the Authority will not fund voucher payments for Pre-Registered Packages which have been contracted after this 2 Working Day period.
- 14. Information sharing**
- 14.1 Information provided to the Authority in connection with the Scheme may be made available to local bodies, Authority agents and the European Commission for purposes connected with the LFFN Programme and/or the RGC Programme but will not otherwise be disclosed to third parties without express permission, except where required by law (including under the Freedom of Information Act 2000 or equivalent legislation).
- 14.2 If Suppliers receive any information request under the Freedom of Information Act 2000 (or equivalent legislation) that concerns the Scheme and/or the Authority the Suppliers shall provide such request to the Authority within 2 Working Days.
- 14.3 Information provided by Suppliers to Beneficiaries (including quotes and invoicing data) under the Scheme may be shared with the Authority or its agents for the purposes of monitoring and fraud prevention.
- 14.4 Information submitted to the Authority by Suppliers (including Beneficiary contact details) may be shared with other associated organisations for the purposes of promoting the Scheme, processing the voucher claims and making payment. Suppliers are required to comply with all applicable Data Protection Laws in force at the relevant time in respect of such information.
- 15. Personal data**

- 15.1 The Authority and the Suppliers shall in relation to the Scheme comply with their respective obligations under the Data Protection Laws, in each case to the extent necessary under those laws.
- 15.2 The Authority and the Suppliers acknowledge that:
- 15.2.1 the Suppliers shall provide contact data of relevant Supplier personnel for use by the Authority in its administration, management, and operation of the Scheme (including for determining eligibility for the Scheme and (where applicable) for the purposes of monitoring, assurance, and fraud prevention) ("**Supplier Contact Data**");
 - 15.2.2 the Authority shall provide contact data of relevant the Authority personal for use by the Suppliers in its administration of, and participation in, the Scheme (including for the purpose of receiving vouchers) ("**Authority Contact Data**"); and
 - 15.2.3 the Suppliers shall provide other Personal Data (including contact data of referee organisations and Beneficiaries) for use by the Authority in its administration, management, and operation of the Scheme (including for determining Supplier eligibility for the Scheme) ("**Other Supplier Data**"). This data shall include but not be limited to: Beneficiary contact name, installation address, email address, company number where relevant, date of agreement, current and planned broadband connection speed, date of order, date of installation.
- 15.3 For the purpose of the Scheme the Authority and the Suppliers agree that:
- 15.3.1 the Suppliers shall be the Controller of:
 - (a) the Supplier Contact Data and the Other Supplier Data for its own internal business purposes; and
 - (b) the Authority Contact Data where it is Processed by the Supplier in accordance with clause 15.2.2; and
 - 15.3.2 the Authority shall be the Controller of:
 - (a) the Authority Contact Data for its own internal business purposes;
 - (b) the Supplier Contact Data where it is Processed by the Authority in accordance with clause 15.2.1; and
 - (c) the Other Supplier Data for: (i) its own internal business purposes; and (ii) the purpose of its administration, management, and operation of the Scheme.
- 15.4 The Authority and the Suppliers shall Process the other party's Contact Data for the purposes set out above in accordance with that party's relevant privacy policy. Each party may be required to share the other party's Contact Data referred to above with its affiliates and other relevant parties, within or outside the country of origin, in order to carry out the activities specified above, but in doing so, each party will ensure that the sharing and use of the Contact Data complies with the Data Protection Laws.

- 15.5 Where acting as the Controller for the purposes of the Contact Data, the Authority and the Suppliers shall make available to the other a copy of their applicable privacy policy and the receiving party shall ensure that this policy is provided to the applicable persons whose Personal Data has been shared with the other party for the purposes set out in these terms.
- 15.6 Where acting as the Controller for the purposes of the Other Supplier Data, the Suppliers shall ensure that all fair processing notices have been given (and/or, as applicable, consents obtained) and are sufficient in scope to allow the supplier to disclose the Other Supplier Data to the Authority in accordance with the Data Protection Laws for its use as anticipated in these terms.
- 15.7 The Authority and the Suppliers warrant, represent and undertakes to the other that they are not subject to any prohibition or restriction which would prevent or restrict them from disclosing or transferring their Contact Data or (in the case of the Suppliers) the Other Supplier Data in accordance with these Terms and Conditions.
- 15.8 Each Supplier shall indemnify on demand and keep indemnified the Authority against any losses incurred by, awarded against or agreed to be paid by the Authority to the extent arising from the relevant Supplier's failure to comply with the Data Protection Laws.

16. **Anti-competitive behaviour**

Suppliers acknowledge that the Scheme operates within the requirements of EU and UK competition law and as such recognise that any anti-competitive behaviour (e.g. bid rigging or collusion) can be prosecuted by the competition authorities. Where breaches of competition law are found, the competition authorities have the power to levy fines against the company and bring criminal actions against individuals (in addition to director disqualification orders).

17. **Waiver**

The rights and remedies of the Authority under or in connection with these Terms and Conditions may be waived only by notice by the Authority and in a manner that expressly states that a waiver is intended.

18. **Severance**

If any provision of these Terms and Conditions is held invalid, illegal or unenforceable for any reason by any court of competent jurisdiction, such provision shall be severed without affecting the remaining provisions.

19. **Governing law**

These Terms and Conditions shall be subject to and construed in accordance with English law and subject to the exclusive jurisdiction of the courts of England and Wales.

Schedule 1 – Definitions

Unless otherwise provided or the context otherwise requires, in these Terms and Conditions the following expressions have the meanings set out below.

Additional Guidance	any applicable guidance set out in the Supplier Guidance Document and/or in any Supplier Bulletin;
Authority	the Department for Digital, Culture, Media and Sport;
Authority Contact Data	has the meaning given in clause 15.2.2;
BDUK	Broadband Delivery UK, being the part of the Authority that is responsible for the management of the Scheme;
Beneficiaries	SME Beneficiaries and Residential Beneficiaries (and Beneficiary refers to any individual one of them);
Beneficiary Contract	each contract entered into between a Supplier and Beneficiary for one or more fibre connections which is supported by one or more vouchers under the Scheme;
Beneficiary Terms and Conditions	the current version from time to time of the Scheme terms and conditions for Beneficiaries;
Connectivity Requirements	the connectivity requirements set out in Schedule 3 – Connectivity Requirements;
Contact Data	the Supplier Contact Data or the Authority Contact Data as applicable;
Controller	has the meaning given in the Data Protection Laws;
Data Protection Laws	<ul style="list-style-type: none"> (a) the GDPR; (b) the Data Protection Act 2018; (c) any code of practice or guidance published by the ICO and/or the European Data Protection Board from time to time; and (d) all other applicable data protection laws
Eligible Costs	has the meaning given in paragraph 1.1 of Schedule 4 – Eligible Costs;
Gigabit Capable	the relevant connection is capable of delivering at least 1Gb connectivity using any technology (upload or download, not necessarily at the same time);

GDPR	Regulation (EU) 2016/679 of the European Parliament and of the Council of 27 April 2016 on the protection of natural persons with regard to the processing of personal data and repealing Directive 95/46/EC (General Data Protection Regulation) OJ L 119/1, 4.5.2016;
Issue Escalation Procedure	the procedure described in Schedule 6 – Issue Escalation Procedure;
LFFN Programme	the Local Full Fibre Networks programme, being the Authority's programme to stimulate commercial investment in full fibre infrastructure within the UK;
Other Supplier Data	has the meaning given in clause 15.2.3;
Personal Data	has the meaning given in the Data Protection Laws;
Pre-Registered Package	each package of products authorised by the Authority in accordance with clause 6.4, which is either a Standard PRP or a Project PRP;
Premise	a building in the UK which attracts either council tax or business rates;
Process	has the meaning given in the Data Protection Laws;
Processed	has the meaning given in the Data Protection Laws;
Project PRP	Pre-Registered Packages comprising location specific projects (e.g. business parks, villages, multi-occupancy Premises) and multiple Beneficiaries, where the magnitude of the Eligible Costs varies significantly between projects and is always greater than the applicable individual voucher financial limit (i.e. it is dependent upon the aggregation of multiple vouchers);
RGC Programme	the Authority's Rural Gigabit Connectivity programme;
RGC Projects	Project PRPs benefiting from vouchers under the Scheme which contain Rural Premises and are identified by the Authority as eligible for the RGC Programme;
Residential Beneficiary	a resident in the UK that meets the Residential Beneficiary requirements set out in Schedule 2 – Beneficiary Eligibility and is eligible to benefit from vouchers under the Scheme;

Rural Premises	<p>Premises which comply with the following:</p> <p>(a) in England and Wales, premises classifications D-F inclusive as defined within the Office for National Statistics publication "The 2011 Rural-Urban Classification For Small Area Geographies";</p> <p>(b) in Northern Ireland, premises classifications E-H inclusive as defined by the Review of the Statistical Classification and Delineation of Settlements, Northern Ireland Statistics and Research Agency (as updated from time to time); or</p> <p>(c) in Scotland, premises classifications 3-8 inclusive as defined within Scottish Government Urban Rural Classification 2013-2014 (as updated from time to time);</p>
Scheme	has the meaning given on page 3 of these Terms and Conditions;
SME	the small and medium-sized enterprises described in paragraph 1.1.1 of Schedule 2 – Beneficiary Eligibility;
SME Beneficiary	a SME trading in the UK that meets the SME Beneficiary requirements set out in Schedule 2 – Beneficiary Eligibility and is eligible to benefit from vouchers under the Scheme;
Standard PRP	Pre-Registered Packages where typically the Eligible Costs are either fixed for each deployment (or vary within known parameters). These packages are registered once by Suppliers and then can be deployed as individual connections. The package can be replicated at other premises in eligible areas. Beneficiaries for these packages are individual SMEs. These products must be available to non-voucher customers (albeit on adjusted commercial terms to the Beneficiary which reflect the value of the voucher contribution). Standard PRPs are for the benefit of SME Beneficiaries only (not Residential Beneficiaries);
State Aid Intervention	delivery (or planned delivery) of an Gigabit Capable connection under either the <i>United Kingdom National Broadband scheme for the UK</i> (SA.33671 (2012/N)) or the <i>National Broadband Scheme for the UK for 2016-2020</i> (SA. 40720 (2016/N));
Supplier	each supplier that the Authority has confirmed in writing is registered to the Scheme following the Authority's review of the relevant supplier's registration application;
Supplier Bulletin	each bulletin issued by the Authority to the Suppliers relating to the Scheme;

Supplier Contact	the individual (with associated email address) notified by the Supplier from time to time (using LFFNSuppliers@culture.gov.uk) who shall be the main Supplier point of contact for the Authority for all matters relating to the Scheme and have the additional responsibilities set out in clause 4.1.4;
Supplier Contact Data	has the meaning given in clause 15.2.1;
Supplier Guidance Document	the Scheme document entitled "Supplier Guidance" made available to Suppliers as may be updated and notified by the Authority from time to time;
Terms and Conditions	these terms and conditions (including the Schedules) as may be updated by the Authority in writing from time to time;
Welsh Projects	Project PRPs benefiting from vouchers under the Scheme which are identified by the Authority as being Project PRPs in Wales;
Working Day	any day other than a Saturday, Sunday or public holiday in the jurisdiction of the party affected by the relevant Working Day provision.

Schedule 2 – Beneficiary Eligibility

1. SME Beneficiaries

1.1 Organisations may be SME Beneficiaries only if Suppliers provide the Authority with the information set out in paragraph 4 of this Schedule and establish that:

1.1.1 the organisation meets the European Commission definition of SME (details at http://ec.europa.eu/growth/smes/business-friendly-environment/sme-definition_en), which can be summarised as:

(a) up to 249 employees (in total in the organisation) and turnover no greater than €50m per annum; and/or

(b) balance sheet of no more than €43,000,000.

1.1.2 the organisation has not received a previous voucher under the Scheme. SME Beneficiaries may benefit from multiple connections supported by the Scheme at different locations, but no SME Beneficiary may benefit by more than £2,500 in total;

1.1.3 as a result of the voucher contribution included within the relevant package, the organisation will have received less than €200,000 in public grants in the last 3 years from date of contracting for the relevant package) (see Note 1 below);

1.1.4 the organisation will receive the requisite step-change in service (as described in the Connectivity Requirements) as a result of contracting for the relevant Pre-Registered Package;

1.1.5 the organisation is **not**:

(a) owned, linked through ownership or controlled by any Supplier;

(b) a school funded by the Department for Education;

(c) a public sector organisation;

(d) a privately funded school operating between the ages of 3-18; and/or

(e) an organisation solely involved in offering provision under the requirement for young people to remain in education or training until their 18th birthday; and

1.1.6 the organisation has confirmed that they are content for their voucher to be used as part of the relevant Pre-Registered Package.

1.2 Where multiple organisations operate from the same shared location, the Authority reserves the right to limit the number of SME Beneficiaries in the location.

2. Residential Beneficiaries

2.1 Residential Beneficiaries may only benefit from the Scheme if Suppliers provide the Authority with the information set out in paragraph 4 of this Schedule and establish that:

- 2.1.1 the relevant Residential Beneficiary has not already received (and/or will not receive) voucher funding under the Scheme which exceeds the Scheme's maximum applicable voucher value;
- 2.1.2 the relevant Residential Beneficiary will receive the requisite step-change in service (as described in the Connectivity Requirements) as a result of contracting for the relevant Pre-Registered Package; and
- 2.1.3 for Project PRPs, the relevant Supplier has confirmed that the relevant Residential Beneficiary is content for their voucher to be used as part of the Project PRP.

3. **Beneficiary confirmation**

Suppliers shall procure that Beneficiaries confirm their eligibility details and acceptance of the Beneficiary Terms and Conditions through the Scheme's web portal. Vouchers will not be issued by the Authority until this confirmation has been received. **Suppliers should note that a Beneficiary's voucher funding will only be confirmed as available after this step has taken place.**

4. **Supplier reporting**

- 4.1 Suppliers must report the following information to the Authority within 10 days of the date of each Beneficiary Contract and/or the date of the relevant Beneficiary's connection:
 - 4.1.1 company name (where applicable);
 - 4.1.2 Beneficiary contact name;
 - 4.1.3 Supplier's unique customer reference number for the Beneficiary Contract;
 - 4.1.4 voucher number – provided by Authority portal;
 - 4.1.5 installation address;
 - 4.1.6 installation postcode;
 - 4.1.7 Beneficiary email address;
 - 4.1.8 Beneficiary contact number;
 - 4.1.9 Pre-Registered Package reference;
 - 4.1.10 value of voucher claimed (actual Eligible Costs incurred as set out in the Pre-Registered Package);
 - 4.1.11 existing connection speed (upload/download);
 - 4.1.12 nature of previous connection (contended/uncontended);
 - 4.1.13 new connection speed (when not fixed for the relevant Pre-Registered Package);
 - 4.1.14 date Beneficiary Contract signed (date of sale); and

4.1.15 connection date (when completed).

5. **De-Minimis notification**

The Authority will issue a "De-Minimis" letter to relevant Beneficiaries when installations have been completed and payment has been made to the relevant Supplier which outlines the nature and value of the grant aid they have received. Residential Beneficiaries will receive a notification of benefit.

Schedule 3 – Connectivity Requirements

1. All connections supported by vouchers under the Scheme must fulfil **BOTH** of the following characteristics:
 - 1.1 be Gigabit Capable at the time of delivery of the connection without the need for future hardware upgrades or modification (excluding Customer Premises Equipment (CPE) – it is not mandatory to deploy Gigabit Capable CPE from the outset if this is not required to deliver service, unless the CPE is embedded into the Network Terminating Equipment (NTE) which must be Gigabit Capable); and
 - 1.2 deliver a minimum of 100Mbit/s to the Beneficiary's Premises. The upgraded broadband service must deliver a "step change" in service which is at least a doubling of speeds compared to the service currently being consumed (either upload or download).
2. Any Premise with an existing connection that is already Gigabit Capable is **NOT** eligible to benefit from a voucher under the Scheme whether or not that connection is currently in use.
3. Connections which use wireless technology to meet the Connectivity Requirements will **only** be permitted where included as part of an authorised Project PRP and which leads to the deployment of additional full fibre.
4. In order to be eligible for the Scheme, once the final connection has been made to a Beneficiary's Premise and the Beneficiary is taking services, the Supplier must confirm that the infrastructure supporting their service is Gigabit Capable within 10 Working Days of a valid retail/wholesale upgrade order (or the minimal timescale which may be achieved due to external regulatory constraints) with no additional capital/infrastructure/passive equipment upgrades required (excluding CPE).

Schedule 4 – Eligible Costs

1. Introduction

1.1 For the purpose of the Scheme "**Eligible Costs**" means the full, or the significant part of, the directly attributable incremental costs (that are capable of being capitalised under generally accepted accounting practices in the UK) of connecting Beneficiaries to commercially deployed access infrastructure to enable Beneficiaries to obtain the high-speed/high-grade service capability they require, which meet the Connectivity Requirements and as such costs are further described in this Schedule 4.

1.2 In particular, vouchers can be used by Suppliers to provide customers with a step-change in service, which can be obtained either through the provision of new connectivity using LFFN Programme or RGC Programme qualifying NGA Networks (including the use of wired or wireless technologies) (see Note 1 below) or the provision of business grade connectivity (leased line capability/microwave) (see Note 2 below).

1.3 Wireless technologies are eligible for the Scheme only when included as part of an agreed Project PRP and which leads to the deployment of additional full fibre.

1.4 **In accordance with these Terms and Conditions, Suppliers are responsible for ensuring that all claims submitted for voucher funding relate to Eligible Costs only, and should seek further guidance from the Authority if necessary before submitting claims for payment.**

1.5 Broadly, the lines of demarcation in the network that qualify for subsidy are:

1.5.1 **Network side:** The downstream port of the nearest point of significant aggregation to a customer's Network Terminating Equipment (NTE); and

1.5.2 **Customer side:** the customer-side ports (or wireless antenna) of the Network Termination Equipment (NTE) to which a Network Communicating Equipment (NCE) is connected.

1.6 This is further illustrated by reference to the diagrams below, which apply these demarcation principles to various types of network deployment:

1. Typical Deployment (Fibre)

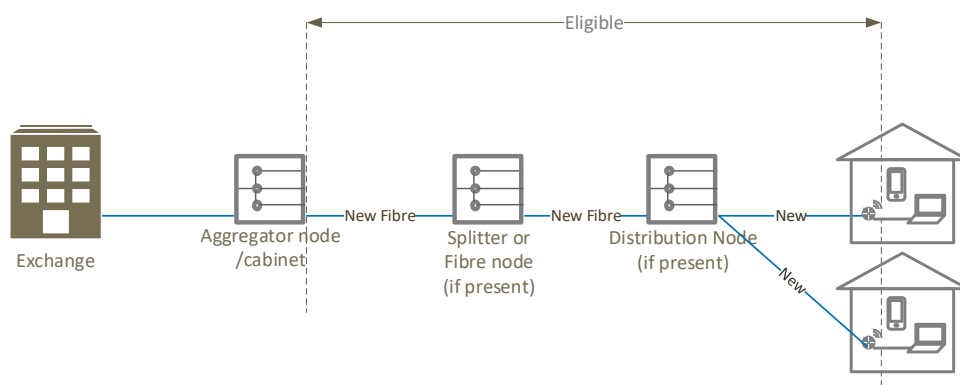

2a Example Deployment (Wireless)

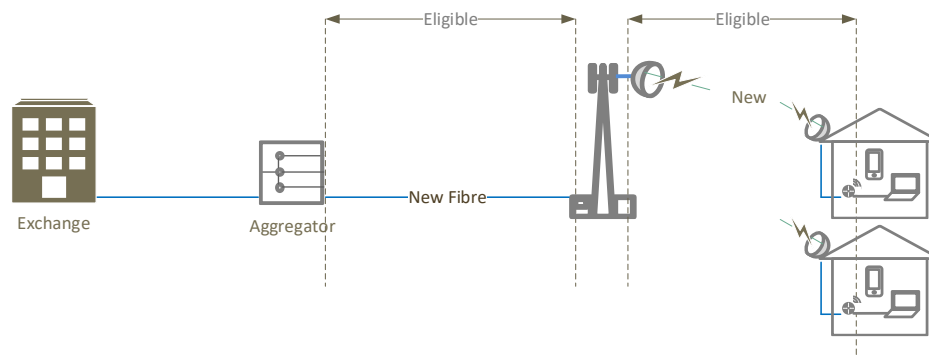

2b Example Deployment (Wireless)

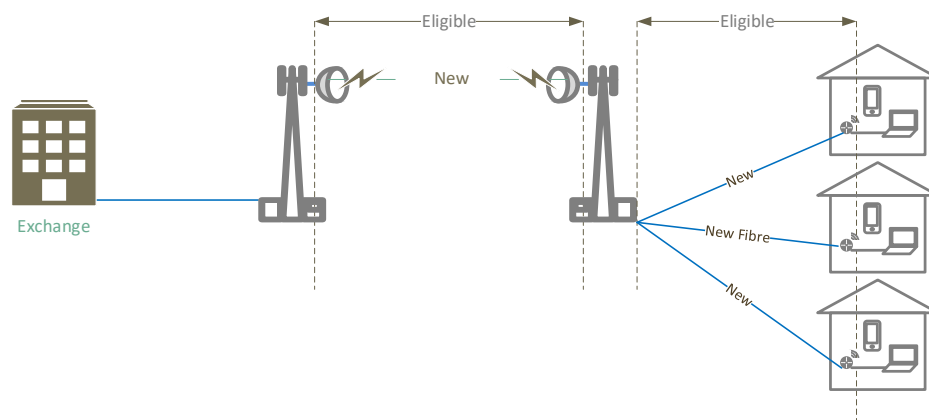

2c Example Deployment (Wireless)

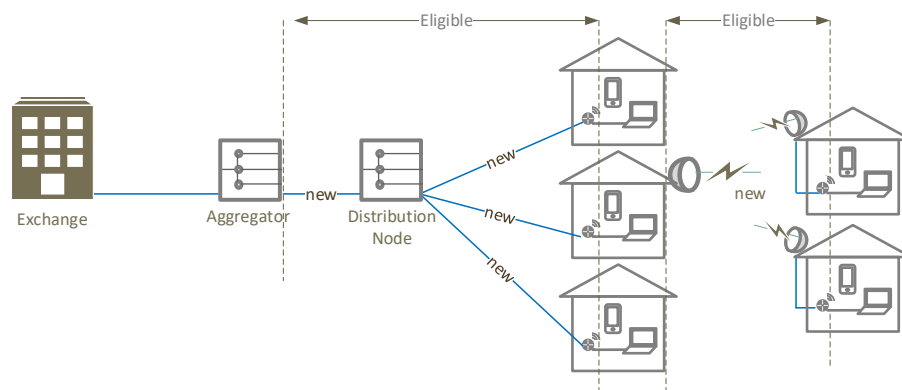

- 1.7 Passive and powered splitters/combiners, amplifiers, repeaters and regenerators which do not provide a switching/routing function that are within these lines of demarcation **qualify for subsidy**, as do other intermediate items that are required to provide the requisite service, as described below.
- 1.8 Customer Premises Equipment (CPE) or NTE devices which provide a general computing function beyond supporting a network data service **do not qualify** for subsidy, including most NCE devices, firewalls, telephones, tablets, laptops and PCs. By contrast CPE devices that **only** provide a networking function, including modems, qualify. Only one wireless access point as part of the CPE may qualify. The maximum contribution made to the cost of any CPE by the voucher is £250 ex VAT. 4G dongles, or internal 4G modules for laptops, do not qualify.

In addition to the cap of £250 for CPE, the contribution made by a voucher to the costs of active switching equipment for multi-occupancy buildings or sites is capped at **£500** ex VAT per voucher (i.e. a total maximum contribution of £750 ex VAT for CPE and active equipment).

1.9 While the precise categories of Eligible Costs will be dependent on the solutions offered to the Beneficiaries the categories of Eligible Costs provided below are intended to provide Suppliers with an indication of the **likely** qualifying items.

1.10 The Authority reserves the right at its absolute discretion to deem any cost ineligible as part of a Pre-Registered Package proposal where that cost is inconsistent with the Scheme's aim of supporting new gigabit capability in the UK.

2. **Eligible Costs**

2.1 The costs set out below are non-exhaustive examples of Eligible Costs.

Eligible network connection costs (for all types of connection)

- planning, survey, acquisition, site preparation, installation, and commissioning fees. Note that the maximum contribution made by the voucher for the costs of any survey works is **£250** ex VAT;
- provision of building entry points and (including breaking/drilling charges for entry through external and internal walls), trunking and tray work (within end-user's curtilage) and fibre cable and jointing;
- necessary supporting structures including poles and other mountings, brackets, fixings, and associated civil works (including craneage);
- power supplies equipment to support network electronics and optics, including power company connection costs, but excluding any CPE power supplies beyond an existing 240V AC socket;
- fibre optic cables, sheaths, connectors, joints, splitters and enclosures,, microwave feeders, jumpers, connectors, antenna radomes and enclosures, lightning protection devices, and electrical earthing systems;
- adapters/converters to ensure that all the pre-existing communications functionality is effectively maintained (e.g. adapters/converters for analogue telephones, dialup modems, alarm diallers or other devices that may contain embedded modems such as medical alarms)

Eligible business connectivity (fibre) connection costs (for fixed connections only)

- provision of new footway and carriage boxes, poles and duct infrastructure;
- CPE (e.g. Optical Network Terminal (ONT) or fibre modem), backup battery, patch panel and residential gateway and associated intermediate power and fibre communications cables).

Eligible Network connection costs (wireless solutions only)

- provision of building location points (including all associated mounting costs);
- Radio Frequency (RF) connectors, splitters, combiners, duplexers, filters, antennas, radomes and enclosures;

- External wireless repeaters if necessary for coverage; and
- provision of building location points (including all associated mounting costs); and
- wireless CPE costs.

3. Excluded Costs

3.1 The following costs are non-exhaustive examples of costs that do not qualify as being Eligible Costs:

- SME connections to basic broadband technologies (see Note 4 below);
- bonded VDSL connections
- additional charges for expedited connection e.g. time related charges (TRCs);
- cancellation fees for any pre-existing connection or contract;
- cabling on the customer side of the CPE to support (e.g. in-Premise installation of cat5e and RG6 coax cable or more than one wireless access point);
- inter-site connectivity;
- historic capital costs associated with network deployment (excepting where these have been demonstrably deployed at risk by the CP in anticipation of Beneficiaries using vouchers to access the network since the launch of the Scheme);
- any of the network elements that may require upgrading to support the final connection e.g. 'middle' mile/trunk and core upgrades that are required to support the final connection;
- costs related to the purchase of wayleaves or other easement rights (see Note 3 below);
- operational expenditures and overheads (Opex), save for those that are direct incremental and one-off costs associated with the installation of the new high-speed / high-grade connection;
- operating lease rentals, general corporate or unabsorbed overheads, interest and financing charges;
- wayleaves;
- demand surveys, marketing & other sales costs.

Explanatory Notes:

Note 1: NGA Networks are access networks which rely wholly or partly on optical elements (coaxial, wireless and mobile technologies make use, to a certain extent, of a fibre support infrastructure, thereby making them conceptually similar to a wired network using copper to deliver the service for the part of the last mile not covered by fibre) and which are capable of delivering broadband access services with enhanced characteristics as compared to existing basic broadband networks. (The final connection to the end-user may be ensured both by wired and wireless technologies. Given the rapid evolution of advanced wireless technologies such as LTE-Advanced and the intensifying market deployment of LTE and Wi-Fi, next generation fixed wireless access (e.g. based on possibly tailored mobile broadband technology) could qualify as NGA Networks. Next generation wireless access based on tailored mobile broadband technology must also ensure the quality of service level required by the customer at a fixed location while serving any other nomadic subscribers in the area of interest. Wireless technologies are only permitted when included as part of an agreed Project Pre-Registered Package and which leads to the deployment of additional full fibre.

Note 2: Business grade services being those uncontended capabilities connecting a SME site to a point in the supplying communications provider's network (e.g. partial private circuits or microwave link) and are supported with service level guarantees.

Note 3: Wayleave and easement rights being payments made to landowners for the legal right to access that land in order to install and maintain communications cabling and piping. For example, see Openreach charges for connection at: <https://bit.ly/1Ly71hV>

Note 4: Several different technology platforms can be considered as basic broadband networks including asymmetric digital subscriber lines (up to ADSL2+ networks), non-enhanced cable (e.g. DOCSIS 2.0), mobile networks of third generation (UMTS) and satellite systems.

Schedule 5 – Scheme Marketing and Promotion Protocol

1. Introduction

This protocol aims to ensure there is clear understanding of how Suppliers should present their involvement in the Scheme, how media enquiries should be handled and when announcements need to be flagged to all parties involved.

2. Media Enquiries

Suppliers shall respond to all local and regional specific enquiries as they are best placed to provide this information. General questions about nationwide government programmes should be directed to the Authority by contacting our general enquiries email at enquiries@culture.gov.uk. Suppliers may respond to questions relating to the specific work they are undertaking and general broadband enquiries. When responding to queries or promoting the Scheme Suppliers should state the contribution being made by the Authority, and when doing so may use the Authority's logo and branding in accordance with the guidance below. Any material disseminated by a Supplier with Authority or UK Government branding or logos must be signed off by the Authority before release. The sign-off process is to send all proposed documents for release to LFFNSuppliers@culture.gov.uk.

3. Social Media

The Authority's press team are keen to support announcements through social media and ministers are happy to re-tweet where appropriate. If space permits and where appropriate, we would encourage the Authority funding to be referenced in tweets and social media content, linking to Authority social media accounts on Twitter (@dcms) and Facebook ([facebook.com/dcmsgovuk](https://www.facebook.com/dcmsgovuk)). To help us join up, we suggest Suppliers follow us on Twitter and like us on Facebook so we can follow them back and also look out for retweets and content to share.

4. Press Releases

All parties (the Authority, relevant Suppliers, and local bodies and devolved administrations if applicable) need to approve, and be offered an opportunity to provide a quote for inclusion in, any press release relating to the following:

- Supplier registration;
- projects and connections commenced or delivered; and
- any other significant milestones being reached.

All press releases or public announcements should be approved by BDUK – please email copies to LFFNSuppliers@culture.gov.uk. Whilst comments or quotes are rarely added BDUK still needs to be aware of, and approve, any planned communications activity. Please ensure you allow sufficient time for feedback/approval from BDUK.

5. Use of Logos/Brands and References to the Scheme

The Authority will make logos available for Suppliers through the Scheme portal. These may be found at <https://gigabitvoucher.gov.uk/media> and are only accessible to users with sign in access to the site.

The following guidelines **must** be followed when using these logos or references to the Scheme:

- The use of the logo must not imply any endorsement of one Supplier over another.
- The logo must be of equal size to other partner logos.
- Suppliers with registered PRPs may present them to their customers as "available with support from DCMS".
- Suppliers must NOT present themselves or any Pre-Registered Package products as "approved" by the Authority nor infer that Authority agreement to a Project PRP implies any sole supplier rights for the relevant location.
- The logos may not be used following the end of the Scheme and/or the LFFN Programme or the cessation of the relevant Supplier's involvement in it.
- Placement of the logos must not imply any other accreditation or support of the supplier or its products other than the agreed Scheme.
- The Authority reserves the right to have a quote included in any press release associated with the Scheme and/or the LFFN Programme.

Suppliers should **only** describe their involvement in the Scheme as "Registered Supplier" and any Pre-Registered Packages as "authorised". Further guidance and examples of how to use these logos can be found on the Scheme's portal to which Suppliers will be given access.

The right for Suppliers to use the logos are under a non-exclusive licence only and do not confer upon Suppliers any right or interest in the logos other than as set out in these terms. Logos should be used only as provided through the Scheme portal.

Suppliers must not do, nor cause or authorise to be done: (i) anything which shall impair, damage or be detrimental to the reputation or goodwill associated with the Authority, the Scheme, the LFFN Programme and/or the logos; or (ii) anything which may adversely affect the value of the logos or their registration. The logos shall not be altered in any way without prior written consent from the Authority and the Suppliers shall ensure that any reproduction under these terms shall be a true and exact replica of the relevant logos.

Suppliers authorise the Authority to use their logo on the Scheme website and to link to their websites.

Schedule 6 – Issue Escalation Procedure

1. Issues

- 1.1 The following procedure will be followed if there are issues arising with any Supplier in respect of the Scheme, such issues including but not limited to:
- 1.1.1 provision of Pre-Registered Project proposals, quotes or invoices which have been identified as suspicious by Authority anti-fraud procedures;
 - 1.1.2 provision of quotes or invoices which seek to secure voucher funding for costs which have not been genuinely incurred or are not Eligible Costs;
 - 1.1.3 provision of invoices for costs which are not consistent with commercial rates for comparable installations;
 - 1.1.4 instances of suspected or actual collusion between Suppliers;
 - 1.1.5 any Supplier behaviour which the Authority considers to be inappropriate within the context of the Scheme and/or these Terms and Conditions; and/or
 - 1.1.6 any suspected or actual breach of these Terms and Conditions.

2. Procedure

- 2.1 Following an initial investigation by the Authority and/or the relevant local body, or the Authority's appointed agent, without prejudice to any rights or remedies of the Authority under these Terms and Conditions or in law one of the following courses of action will be followed:
- 2.1.1 Do nothing – the Authority's assessment determines that no further action is required.
 - 2.1.2 Monitor – the Authority's assessment determines that the Supplier(s) in question should be monitored for an agreed period of time before determining if action is required.
 - 2.1.3 Investigate – the Authority's assessment determines that further investigation of the issue is required. The Authority's Senior Responsible Officer (SRO) will be notified.
- 2.2 **Suppliers should note that, should the Authority reasonably believe that public funding may be at risk, then the Authority reserves the right to immediately suspend relevant Suppliers from the Scheme (and cease further payments to those Suppliers) pending further investigations.**
- 2.3 If further investigations are deemed necessary, the relevant Supplier will be contacted in writing by the Authority and asked to provide clarification of the issue within 5 Working Days of receipt of the Authority's notification.
- 2.4 On receipt of the Supplier's response, the Supplier may be invited to attend a meeting with the Authority and/or the relevant local body to discuss the nature of the issue and the clarifications received.

- 2.5 Following completion of investigations (which may involve further discussions with the Supplier and the provision of further information by the Supplier) a written report will be prepared by the Authority. Depending on the specific nature of the issue, without prejudice to any rights or remedies of the Authority under these Terms and Conditions or in law the course of action that the Authority may take may include any one or all of:
- 2.5.1 No action required – case closed.
 - 2.5.2 The Authority issuing clarification of guidance to all relevant local bodies.
 - 2.5.3 The Authority issuing clarification of guidance to the Supplier(s) concerned.
 - 2.5.4 The Authority issuing updated guidance to all Suppliers.
 - 2.5.5 The Authority amending the design of the Scheme.
 - 2.5.6 The Authority determining special measures for the Supplier(s) in question, such as an increased frequency of audits.
 - 2.5.7 The Authority removing the Supplier(s) from participation in the Scheme.
 - 2.5.8 The Authority seeking to recover funds from the Supplier(s) concerned or administering other sanctions on the Supplier, as deemed appropriate (such as referring the Supplier to the relevant authorities or using an external debt recovery agency).
- 2.6 Suppliers will have a right of appeal to the BDUK Chief Executive, if required. Otherwise, any decision made by the Authority under this Issue Escalation Procedure shall be final.

3. **Issues relating to other schemes**

In the event that there are issues arising with any Supplier in respect of any other existing or closed Authority programme or scheme (including without limit the LFFN Programme, the RGC Programme, the Superfast programme and the Better Broadband Scheme), including issues analogous to the issues described in this Issue Escalation Procedure, such that the Authority reasonably believes that public funding may be at risk, then the Authority reserves the right at its discretion to (having completed an investigation) suspend the Supplier from the Scheme, remove the supplier from the Scheme, apply special measures to the Supplier (such as an increased frequency of audits) in respect of the Scheme and/or recover Gigabit voucher funds from the Supplier paid under the Scheme. The Authority may exercise such rights whether or not there are issues arising with the Supplier in respect of the Scheme and such rights shall be without prejudice to, and unaffected by, any rights the Authority may have under or in connection with those other programmes or schemes.

Schedule 7 – RGC Projects

These Terms and Conditions apply to RGC Projects in all respects, except that for RGC Projects:

Part B – Core Terms

Clause 6.5 is replaced with the following: "For SME Beneficiaries vouchers have a minimum value of £500 and a maximum value of £3,500."

Clause 6.7 is replaced with the following: "For Residential Beneficiaries, vouchers have a minimum value of £500 and a maximum value of £1,500."

Clause 6.8 is replaced with the following: "For SME Beneficiaries only, vouchers cannot fund VAT which shall remain the responsibility of the SME Beneficiaries."

Clause 6.12 shall not apply.

Schedule 2

Paragraph 1.1.2 in Schedule 2 is replaced with the following: "The organisation has not received a previous voucher under the Scheme. SME Beneficiaries may benefit from multiple connections supported by the Scheme at different locations, but no SME Beneficiary may benefit by more than £3,500 in total."

The following new paragraph 6 is added to Schedule 2: "The Beneficiary's Premise must be a Rural Premise."

Schedule 3

Paragraph 1.2 in Schedule 3 is replaced with the following: "deliver a minimum of 30Mb/s to the Beneficiary's Premise."

Paragraph 2 in Schedule 3 is replaced with the following: "Any Premise that is capable of receiving a speed of >30 Mb/s is not eligible to benefit from a voucher under the Scheme, whether or not that connection is currently in use."

Schedule 8 – Additional Funding

These Terms and Conditions apply to the projects identified below in all respects, except that the maximum voucher values in respect of the relevant projects are as stated below.

	Projects	Additional Funding
1.	Welsh Projects	The voucher value for: <ul style="list-style-type: none">• SME Beneficiaries is between £500 and £5,500; and• Residential Beneficiaries is between £500 and £800, in each case whilst voucher funding remains available.